



CEP-60

Electric Capstan

The CEP-60 Electric Capstan is a powerful line handling unit with a static bending capacity (at midline) of 75,000 lbs. The 20 HP single-speed CEP-60 includes a reversing electric drive with pushbutton controls, and is configured for bolt-down installation with gearbox, electric motor, and automatic brake all protected below-deck. Components meet ABS, USCG, & IEEE-45 Rules.

WINCH SYSTEM SPECIFICATIONS

- ◆ Max. Line Pull: 34,880 lbs (stall), 10,260 lbs @ 55 ft/min.
- ◆ Barrel Dimensions: 18" dia. x 18" high (working surface).
- ◆ Electric Motor & Drive: 20 HP marine-duty motor with space heater.
- ◆ Braking Capacity: Spring-set auto-brake rated at 140% of motor torque.
- ◆ Power Control: 3-pushbutton NEMA-4X control station (Forward, Stop, Reverse).
- ◆ Power Requirements: 460VAC 3 Phase, 60Hz, 15A. Other source voltage options available.
- ◆ Approximate Weight: 3,400 lbs.
- ◆ General Dimensions: 91.8" H (39.2" above deck) x 38.0" W x 39.0" D.



Markey Machinery Company, Inc.

7266 8th Avenue South, Seattle, WA 98108

Phone: (206) 622-4697 Toll Free (800) 637-3430 Fax: (206) 623-9839

Email: info@markeymachinery.com

Represented by:

Griffin & Associates - 355 Grow Avenue NW, Bainbridge Island, WA 98110 (USA) Phone: 206-780-0509 Email: bagriffin@griffinassociates.com
JH Menge & Company, Inc - 5825 Plache Street, New Orleans, LA 70123 (USA) Phone: 504-733-4871 Email: fclatour@jhmenge.com

Markey CEP-60 Capstan

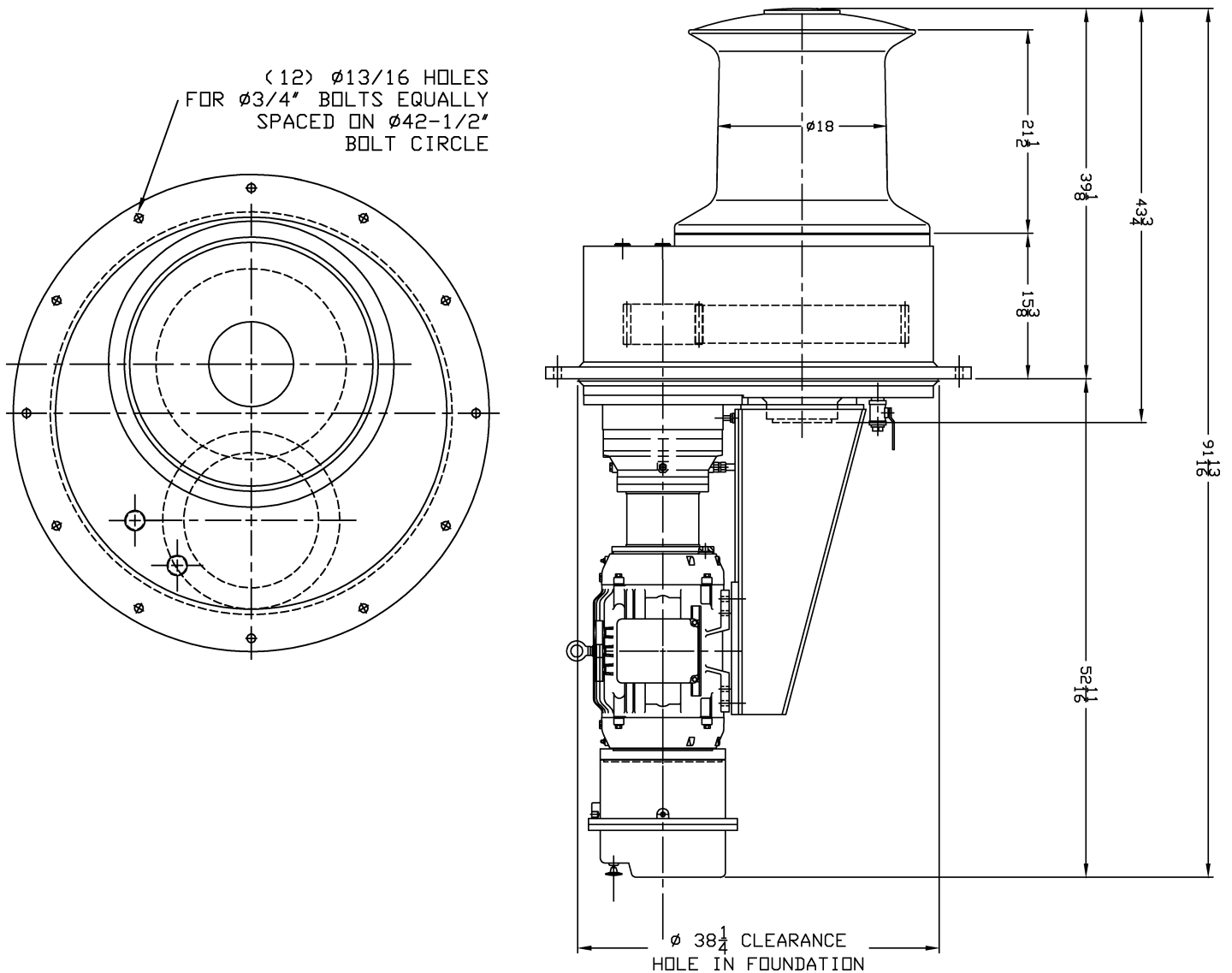

Capstan System Options

- ◆ Hydraulic versions quoted on request
- ◆ Versions available for a variety of source power configurations
- ◆ Performance ratings can be tailored to suit specific applications
- ◆ Single and Multiple-speed models are available
- ◆ Above-deck drive arrangements also available

© 2010

Markey's durable capstans are built to the highest quality workboat standards using materials and processes providing maximum life and minimum maintenance in marine and outdoor applications.



Innovation you can depend on